

M I C R O W A V E
B A S E 2 4 ”

Create BMC24

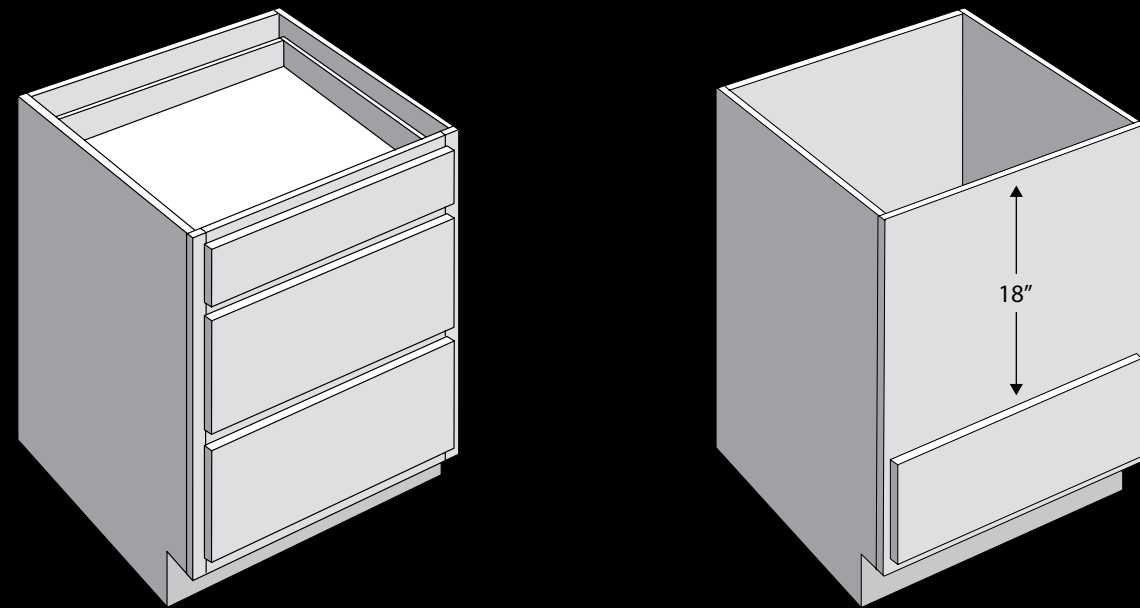

BEFORE → AFTER

M A N Y M O R E M O D I F I C A T I O N S
A V A I L A B L E - P L E A S E C O N T A C T
Y O U R C U S T O M E R S E R V I C E R E P .

A 24" drawer base is modified to create a 24" microwave base. First, the top two drawers are removed. A support shelf is built on top of the bottom drawer, and a full flat panel is applied to

the front, to be cut on job site to fit the microwave (depending on the size of the microwave).